

3 Environmental protection and saving energy

3.1 Disposing of packaging

The packaging materials are environmentally compatible and can be recycled.

- ▶ Sort the individual components by type and dispose of them separately.

3.2 Saving energy

If you follow these instructions, your appliance will use less power.

- Hide the clock in standby mode.
- ✓ The appliance saves energy in standby mode.

4 Familiarising yourself with your appliance

4.1 Control panel

You can use the control panel to configure all functions of your appliance and to obtain information about the operating status.

Note: On certain models, specific details such as colour and shape may differ from those pictured.

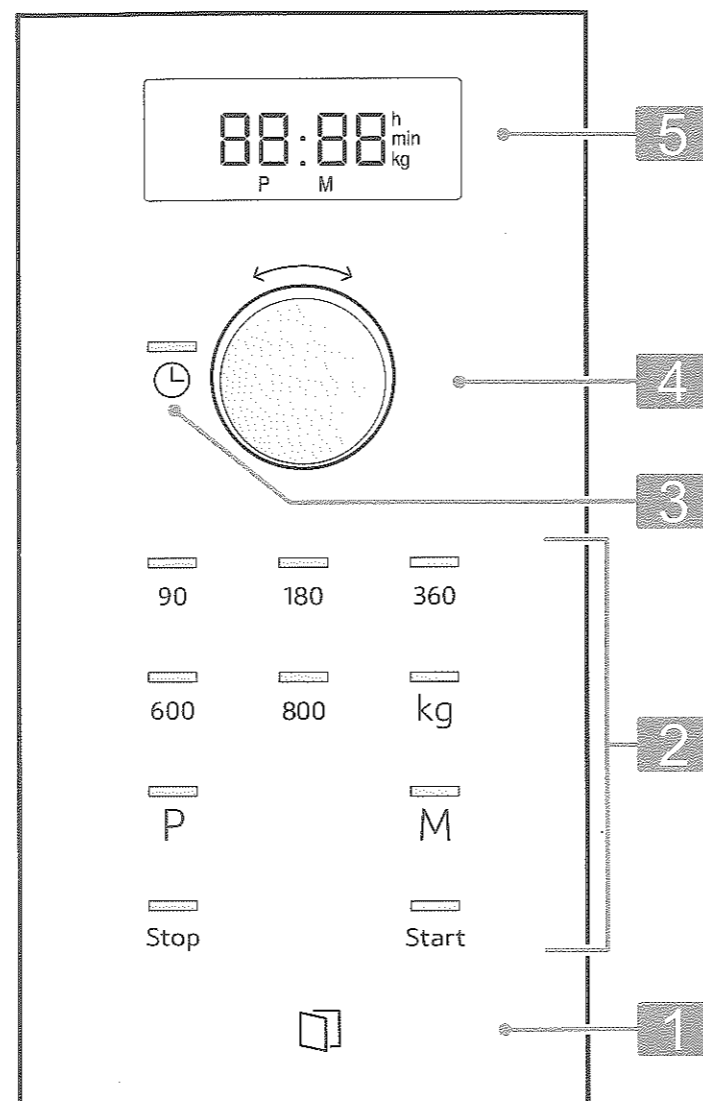

1	Automatic door opener	Open the door automatically.
2	Touch fields	Select functions.
3	Clock button	Set or display the time.
4	Rotary selector	Set the time, cooking time or automatic programmes.
5	Display	Display clock or cooking time.

Rotary selector

Use the rotary selector to change the setting values that are shown on the display.

The rotary selector can be pushed in. To engage or release the rotary selector, push the rotary selector.

Automatic door opener

When you press the automatic door opener, the appliance door springs open. You can fully open the appliance door manually.

Notes

- In the event of a power cut, the automatic door opener does not work. You can open the door manually.

- If you open the appliance door during operation, this pauses the operation.
- When you close the appliance door, the operation does not continue automatically. You must restart the operation.
- If the appliance is switched off for an extended period of time, the appliance door opens with a time delay.

4.2 Types of heating

Here you can find an overview of the types of heating. You can find recommendations on using the types of heating.

Symbol	Name	Use
90-800	Microwave	Defrosting, cooking or heating food and liquids.

4.3 Cooling fan

The cooling fan switches on and off as required. The cooking compartment remains cold during microwave operation. Despite this, the cooling fan will still switch on.

Note: The cooling fan may run on even if the oven has been switched off.

4.4 Condensation

Condensation can occur in the cooking compartment and on the appliance door when cooking. Condensation is normal and does not adversely affect appliance operation. Wipe away the condensation after cooking.

5 Before using for the first time

Configure the settings for initial start-up. Clean the appliance and accessories.

5.1 Initial configuration

Configure the settings for initial start-up. Clean the appliance and accessories.

Note: After connecting the appliance to the power or following a power cut, a signal sounds and several zeros are shown on the display. It may take a few seconds until a signal sounds and you can set the time.

1. Press .
- ✓ 12:00 is shown on the display. The indicator light lights up via .
2. Set the clock using the rotary selector.
3. Press .

5.2 Cleaning the appliance before using it for the first time

Clean the cooking compartment and accessories before using the appliance to prepare food for the first time.

1. Make sure that there is no leftover packaging, accessories or other objects in the cooking compartment.
2. Clean the smooth surfaces in the cooking compartment with a soft, damp cloth.

3. To eliminate the new-appliance smell, wipe the empty cooking compartment with hot soapy water.
→ "Cleaning the cooking compartment", Page 12

5.3 Fitting the turntable

Never use the appliance without the turntable.

1. Place the roller ring into the recess in the cooking compartment.

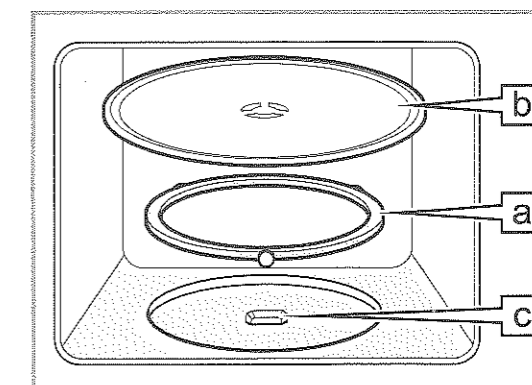

2. Engage the turntable in the drive in the centre of the cooking compartment floor.
3. Check whether the turntable is correctly engaged.

Note: The turntable can turn anti-clockwise or clockwise.

6 Basic operation

6.1 Microwave power settings

This is where you can find an overview of the different microwave output settings and recommendations on when to use them.

Microwave output in watts	Use
90	Defrost delicate foods.
180	Defrost food and continue cooking.
360	Cook meat and fish or heat delicate foods.
600	Heat and cook food.
800	Heat liquids.

Note

You can set the microwave power settings for a particular cooking time:

- 800 W for 30 minutes
- 600 W for 60 minutes
- 90 W, 360 W, 180 W for 99 minutes

6.2 Microwave-safe cookware and accessories

To heat food evenly and avoid damaging your appliance, it is important to use the right cookware and accessories.

Note: Read the manufacturer's instructions before using any cookware in the microwave. If in doubt, carry out a cookware test.

Microwave-safe

Cookware and accessories	Reason
Cookware made from heat-resistant, microwave-safe material: <ul style="list-style-type: none"> ▪ Glass ▪ Glass ceramic ▪ Porcelain ▪ Temperature-resistant plastic ▪ Fully glazed ceramic without cracks 	These materials allow microwaves to pass through. Microwaves do not damage heat-resistant cookware.
Metal cutlery	Note: You can use metal cutlery, e.g. place a spoon in a glass, to prevent delayed boiling.

ATTENTION

Metal touching the wall of the cooking compartment will cause sparks, which may damage the appliance or the inner door pane.

- ▶ Metal (e.g. a spoon in a glass) must be kept at least 2 cm from the cooking compartment walls and the inside of the door.

Not microwave-safe

Cookware and accessories	Reason
Metal cookware	Metal does not allow microwaves to pass through. The food hardly heats up.
Cookware with gold or silver decoration	Microwaves can damage gold and silver decoration. Tip: You can only use this kind of cookware if the manufacturer guarantees that it is microwave-safe.

6.3 Testing cookware for microwave suitability

Test cookware to see whether it is suitable for microwave use. Testing cookware is the only time the appliance should be operated in microwave mode without any food inside.

⚠ WARNING – Risk of scalding!

The accessible parts of the appliance become hot during operation.

- ▶ Never touch these hot parts.
- ▶ Keep children at a safe distance.

1. Place the empty cookware in the cooking compartment.
2. Set the appliance to the maximum microwave power setting for 30 seconds to 1 minute.
3. Start the operation.
4. Check the cookware several times:
 - If the cookware is cold or warm to the touch, it is suitable for microwave use.
 - If the cookware becomes hot or sparks are created, stop the cookware test. The cookware is not microwave-safe.

6.4 Configuring the microwave settings

ATTENTION

Operating the appliance without food in the cooking compartment may lead to overloading.

- ▶ Do not switch on the microwave unless there is food inside. The only exception to this rule is when performing a short cookware test.

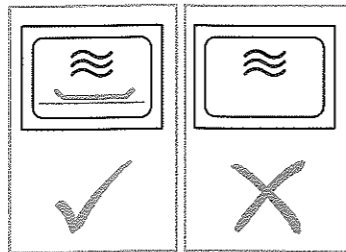

Tip: To ensure optimum use of your appliance, refer to the information in the recommended settings.

→ "How it works", Page 14

1. Follow the safety instructions. → Page 4

2. Read the safety instructions and the section on how to prevent material damage. → Page 5
3. Read the information on microwave-safe cookware and accessories. → Page 8
4. Use the buttons to set the required microwave power setting.
5. Use the rotary selector to set the required duration.

Note: If you open the cooking compartment door during operation, the microwave interrupts the operation and pauses the set time that is counting down. When you close the cooking compartment door, the operation continues.

7 Memory

You can use the memory function to save the setting for a dish and call it up again at any time.

Tip: If you prepare one dish often, use the memory function.

7.1 Saving memory settings

Note

- You cannot save several microwave power settings in succession.
- You cannot save any automatic programmes.

1. Press **M**.
 - ✓ The indicator light lights up via **M**.
2. Use the buttons to set the required microwave power setting.
 - ✓ The indicator lamp above the button lights up and the display shows 1:00 min.
3. Use the rotary selector to set the required duration.
4. If required, select one of the options:
 - ▶ To save the memory and immediately start, press **Start**.

8 Programmes

The programmes help you to use your appliance to prepare different dishes by selecting the optimum settings automatically.

8.1 Setting a programme

1. Select a programme.
2. Press **⊞** repeatedly until the display shows the required programme number.
 - ✓ The indicator light lights up via **⊞**.
3. Press **kg**.
 - ✓ The indicator lamp above **kg** lights up and the display shows a suggested value for the weight.
4. Turn the rotary selector to specify the weight of the dish.

If it is not possible to enter the exact weight, round the weight up or down.

6.5 Changing the cooking time

You can change the cooking time at any time.

- ▶ Use the rotary selector to set the required duration.

6.6 Pausing operation

1. Press **Stop** or open the appliance door.
 - ✓ The indicator light lights up via **Start**.
2. To continue the operation, close the appliance door and press **Start**.

6.7 Cancelling the operation

- ▶ Press **Stop** twice or open the door and press **Stop** once.

- ▶ To save the memory and not start, press **M**.

- ✓ If the appliance does not start, the time appears on the display and the appliance saves the setting.

7.2 Starting the memory

It is very easy to start the saved programme. Place your dish in the appliance and close the appliance door.

1. Press **M**.
 - ✓ The saved settings are displayed.
2. Press **Start**.

7.3 Pausing operation

1. Press **Stop** or open the appliance door.
 - ✓ The indicator light lights up via **Start**.
2. To continue the operation, close the appliance door and press **Start**.

7.4 Cancelling the operation

- ▶ Press **Stop** twice or open the door and press **Stop** once.

5. Press **Start** to start the operation.

- ✓ The cooking time visibly counts down.
- 6. If an audible signal sounds during the programme, open the appliance door.
 - ▶ Break up, stir or turn the food.
 - ▶ Close the appliance door.
 - ▶ Press **Start**.

8.2 Pausing operation

1. Press **Stop** or open the appliance door.
 - ✓ The indicator light lights up via **Start**.
2. To continue the operation, close the appliance door and press **Start**.

8.3 Cancelling the operation

- ▶ Press **Stop** twice or open the door and press **Stop** once.

8.4 Defrosting with the automatic programmes

You can use the four defrosting programmes to defrost meat, poultry and bread.

Programme	Food	Cookware	Weight range in kg
P01	Minced meat	Open	0.20–1.00
P02	Pieces of meat	Open	0.20–1.00
P03	Chicken, chicken pieces	Open	0.40–1.80
P04	Bread	Open	0.20–1.00

Defrosting food using the automatic programmes

- Take the food out of its packaging.
Use food that is stored flat and in portion-sized quantities at -18 °C.
- Weigh the food.
You require the weight in order to set the programme.
- Place the food in a microwaveable shallow dish, e.g. a glass plate or porcelain plate.
Do not put the cover on.
- Set the programme. → Page 9
- Note:** Liquid is produced when you defrost meat and poultry.

- Drain off any liquid when turning and under no circumstances use it for other purposes or allow it to come into contact with other foods.
- Flat pieces of meat and items made from minced meat should be separated from each other before leaving to stand.
- The defrosted food should be left to stand for an additional 10 to 30 minutes until it reaches an even temperature.
Large pieces of meat require a longer standing time than smaller pieces. For poultry, remove the giblets after the resting time.
- Continue to prepare the food, even though thick pieces of meat may still be frozen in the middle.

8.5 Cooking with the automatic programmes

With the three cooking programmes, you can cook rice, potatoes or vegetables.

Programme	Food	Cookware	Weight range in kg	Information
P05	Rice	With lid	0.05–0.20	<ul style="list-style-type: none"> For rice, use a large, deep dish. Do not use any boil-in-the-bag rice. For every 100 g rice, add twice to three times the amount of water.
P06	Potatoes	With lid	0.15–1.00	<ul style="list-style-type: none"> For boiled potatoes, cut fresh potatoes into small, equally sized pieces. Add one tablespoon of water and a little salt for every 100 g boiled potatoes.
P07	Vegetables	With lid	0.15–1.00	<ul style="list-style-type: none"> Weigh fresh, washed vegetables scales. Cut the vegetables into small, uniform pieces. Add one tablespoon of water for every 100 g boiled potatoes.

Cooking food with the automatic programmes

- Weigh the food.
You require the weight in order to set the programme.
- Place the food on microwave-safe cookware and cover with a lid.
- Add the volume of water in accordance with the manufacturer's instructions on the packaging.
- Set the programme. → Page 9
- Once the programme has finished, stir the food again.
- The food should be left to stand for an additional 5 to 10 minutes until it reaches a uniform temperature.
The cooking results are dependent on the food quality and consistency of the food.

9 Basic settings

You can configure the basic settings for your appliance to meet your needs.

9.1 Overview of the basic settings

Here you can find an overview of the basic settings and factory settings. The basic settings depend on the features of your appliance.

Setting	Selection	Meaning
1 Button tone	<ul style="list-style-type: none"> On¹ OFF 	Switch the button tone on and off. Note: The button tone remains active for Start and Stop.
2 Demo mode	d E 0	Activate or deactivate demo mode. Note: The appliance is switched off. You can use the buttons and the display; the buttons do not work. Demo mode is mainly useful for dealers.

9.2 Changing basic settings

Requirement: The appliance is switched off.

- Press and hold Start and Stop for a few seconds.
✓ The display shows the first basic setting.
- Press Start.
✓ The current value flashes on the display.
- Set the desired value with the rotary selector.
- To accept the basic setting, press Start.
- To exit the basic setting, press Stop.
- Use the rotary selector to change to the basic setting 2.
- To edit the basic setting, press Start.
✓ The selected setting lights up on the display.
- Set the desired value with the rotary selector.
- To accept the basic setting, press Start.
- To exit the basic setting, press Stop.
- To exit the basic settings menu, press Stop again.

Tip: The setting can be changed at any time.

9.3 Changing the signal duration

When your appliance is switched off, you hear an audible signal. You can change the duration of the signal.

- Press and hold Start for approx. six seconds.
- ✓ The signal duration switches between short and long.
- ✓ The appliance applies the signal duration and displays the time.

9.4 Setting the time

Note: After connecting the appliance to the power or following a power cut, a signal sounds and several zeros are shown on the display. It may take a few seconds until a signal sounds and you can set the time.

- Press ⊖.
- ✓ 12:00 is shown on the display. The indicator light lights up via ⊖.
- Set the clock using the rotary selector.
- Press ⊖.

9.5 Hiding the clock

To reduce the standby consumption of your appliance, you can hide the clock.

- Press ⊖.
- Press Stop.
To view the clock, press ⊖ again.

10 Cleaning and servicing

To keep your appliance working efficiently for a long time, it is important to clean and maintain it carefully.

10.1 Cleaning products

Only use suitable cleaning agents.

⚠ WARNING – Risk of electric shock!

An ingress of moisture can cause an electric shock.

- Do not use steam- or high-pressure cleaners to clean the appliance.

ATTENTION

Unsuitable cleaning agents damage the surfaces of the appliance.

- Do not use harsh or abrasive cleaning products.
- Do not use cleaning products with a high alcohol content.
- Do not use hard scouring pads or cleaning sponges.
- Do not use any special cleaners for cleaning the appliance while it is hot.
- Only use glass cleaners, glass scrapers or stainless steel care products if recommended in the cleaning instructions for the relevant part.

Salt contained in new sponge cloths may damage surfaces.

- Wash new sponge cloths thoroughly before use.

You can find out which cleaning products are suitable for each surface or part of the appliance in the individual cleaning instructions.

10.2 Cleaning the appliance

Clean the appliance as specified. This will ensure that the different parts and surfaces of the appliance are not damaged by incorrect cleaning or unsuitable cleaning products.

⚠ WARNING – Risk of fire!

Loose food remnants, fat and meat juices may catch fire.

- Before using the appliance, remove the worst of the food residues and remnants from the cooking compartment, heating elements and accessories.

¹ Factory setting (may vary according to model)